

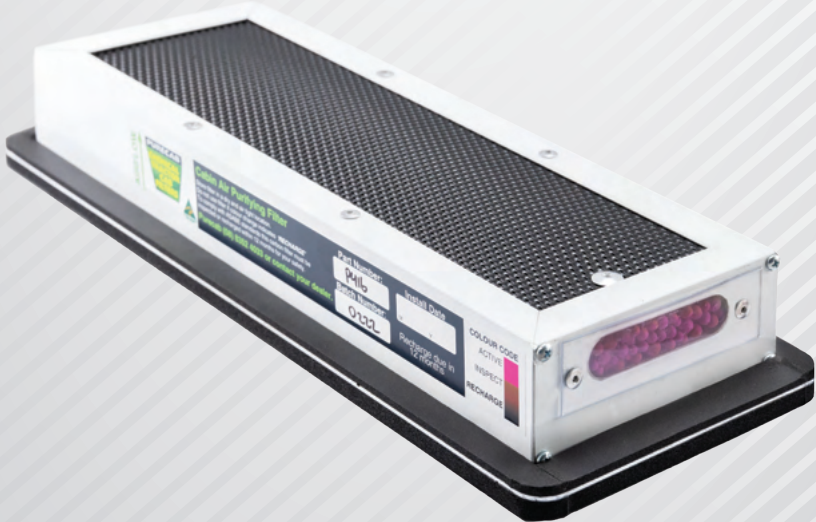

PURECAB

CHEMICAL FILTER RECHARGE KIT



purecab.com

Included in this kit

- ADXORB® Activated Carbon
- Purple indicator beads
- 4 x pop rivets
- 1 x foam dust pad
- 1 x white/pink media
- 1 x clear end cap
- Adhesive backed seals
- Window sticker

Tools required

- ① Drill
- ② Compressed air gun
- ③ Wooden/Rubber mallet
- ④ Rivet gun
- ⑤ Paint scraper
- ⑥ Box cutter
- ⑦ Loctite/superglue

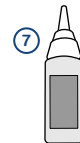
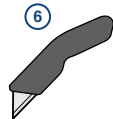
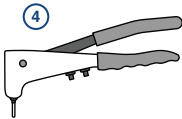
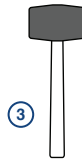
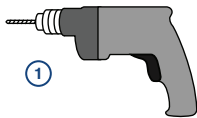

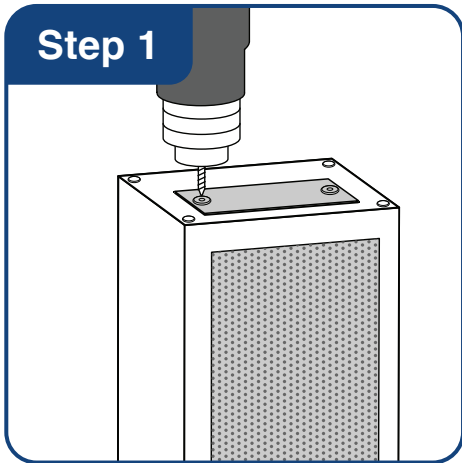

Remove all dust pads. Drill out pop rivets on both end caps and remove the carbon and indicator beads inside. Using compressed air, remove dust and dirt from the filter.



Using a cup or funnel, carefully pour activated carbon into filter.

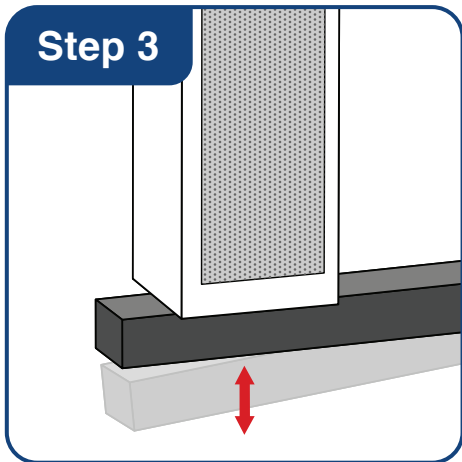

Tap the filter firmly with rubber mallet at base of filter to ensure the carbon is tightly packed. Continue to top up as carbon settles.

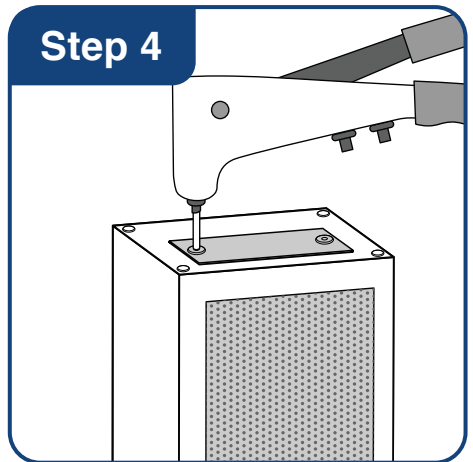

Pop rivet aluminium cap over the activated carbon.

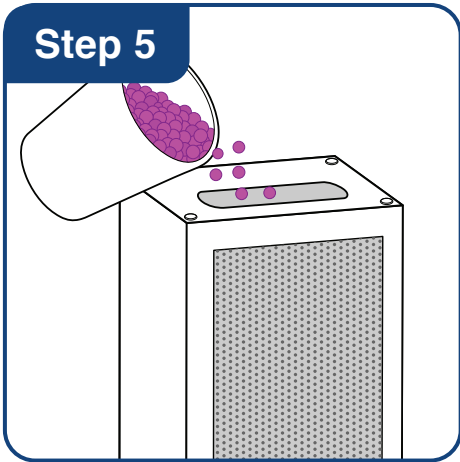

Place purple indicator beads into the small cage at the opposite end of the carbon.

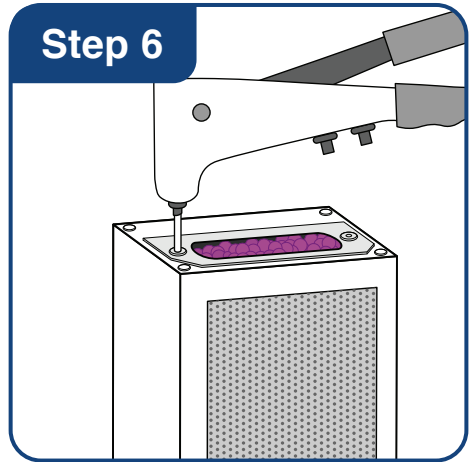

Pop rivet the clear cap over the opening.

Using compressed air, blow out any loose carbon and dust. Wipe filter clean.

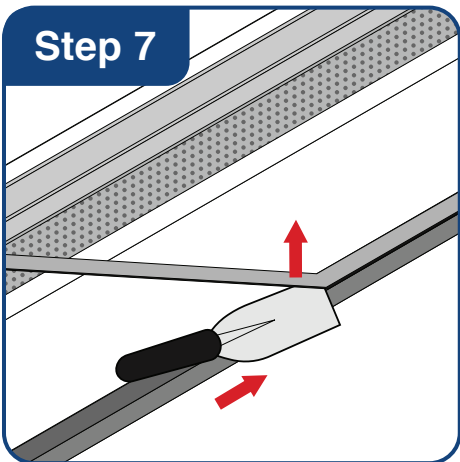

Remove old foam seals from filter, taking note of where seals are placed as some filters will have multiple seals of different sizes. Remove any residual adhesive from the filter.

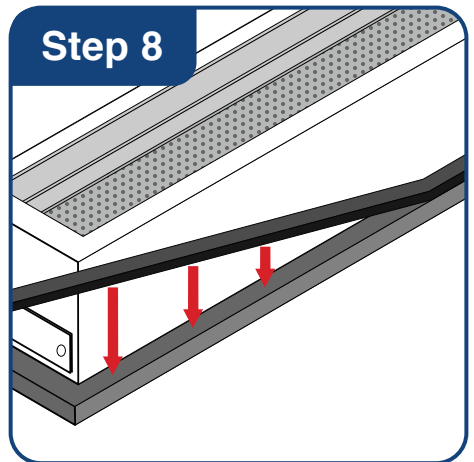

Apply new seals to the correct position on the filter.

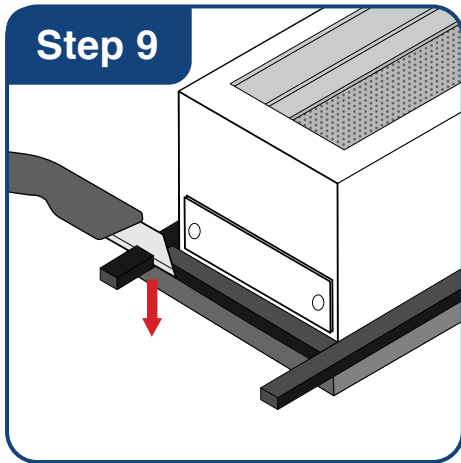

Cut the corners of the seal with a sharp blade to create right angles.

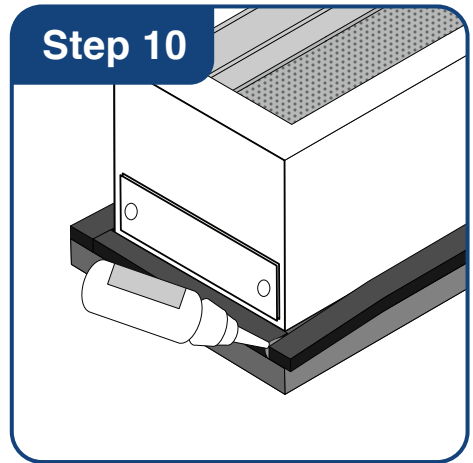

Glue joins of seal together by gently prying two edges apart.

⊛ Glue not provided, any superglue or Loctite will work.

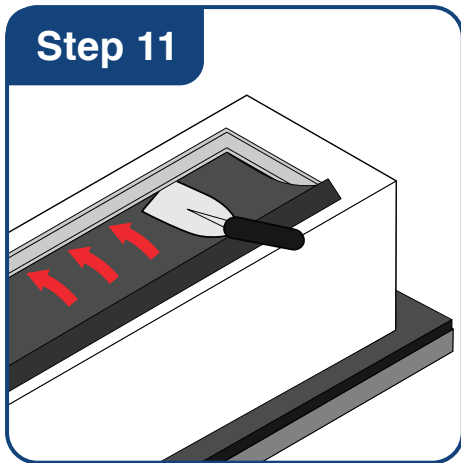

Replace foam dust pads with a small paint scraper, ensuring the pink/white media is closest to the carbon bed with the pink side facing down.



Important: Fill in the date on your window sticker and place the sticker on the window inside your cabin.

Important



Purecab chemical filters with ADXORB® Activated Carbon are proven to exceed USA Standard ASABE S613-3, and are made according to European/UK Standard EN15695-2.

Recent testing proved chemical adsorption was up to **11x** greater in Purecab Filters compared to other brands. The filter's effective life also continued to perform well beyond the required standard duration.

These international standards require filters to be replaced or recharged every 12 months or 400 hours.

To ensure you remain protected, we recommend regular maintenance and inspection.

Please take this time to note the date of installation and place your window sticker in your cabin.

Number: <input type="text"/>		Install Date
<input type="text"/>	M	Y
Number: <input type="text"/>	Recharge due in 12 months	
COLOUR CODE		
	ACTIVE	
	INSPECT	
	RECHARGE	

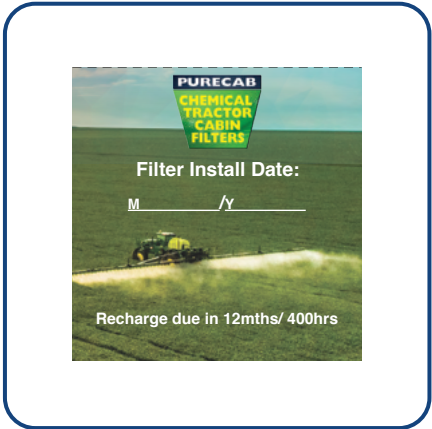



purecab.com